

ASSEM

Für diese technischen Unterlagen behalten wir uns alle Rechte nach DIN ISO 16016 vor				Maßstab: 1:1				
				Maße ohne Toleranzangabe nur zur Information				
				Bear.	14.07.2020	KUDLA	Benennung:	NICHT Freigegeben!
				Gep.			Rollenband AT Vidnal V72	
				Norm				
				DIS:	117166,ZDR,DRW,00		Zeichnungsnummer:	Blatt
				Dr. Hahn® TÜRBÄNDER. MADE IN GERMANY.			90220_0077	1
								3
In.	Änderung	Datum	Name	Urspr.:	Ers.f.	Modell-Nr. 90220_0077		

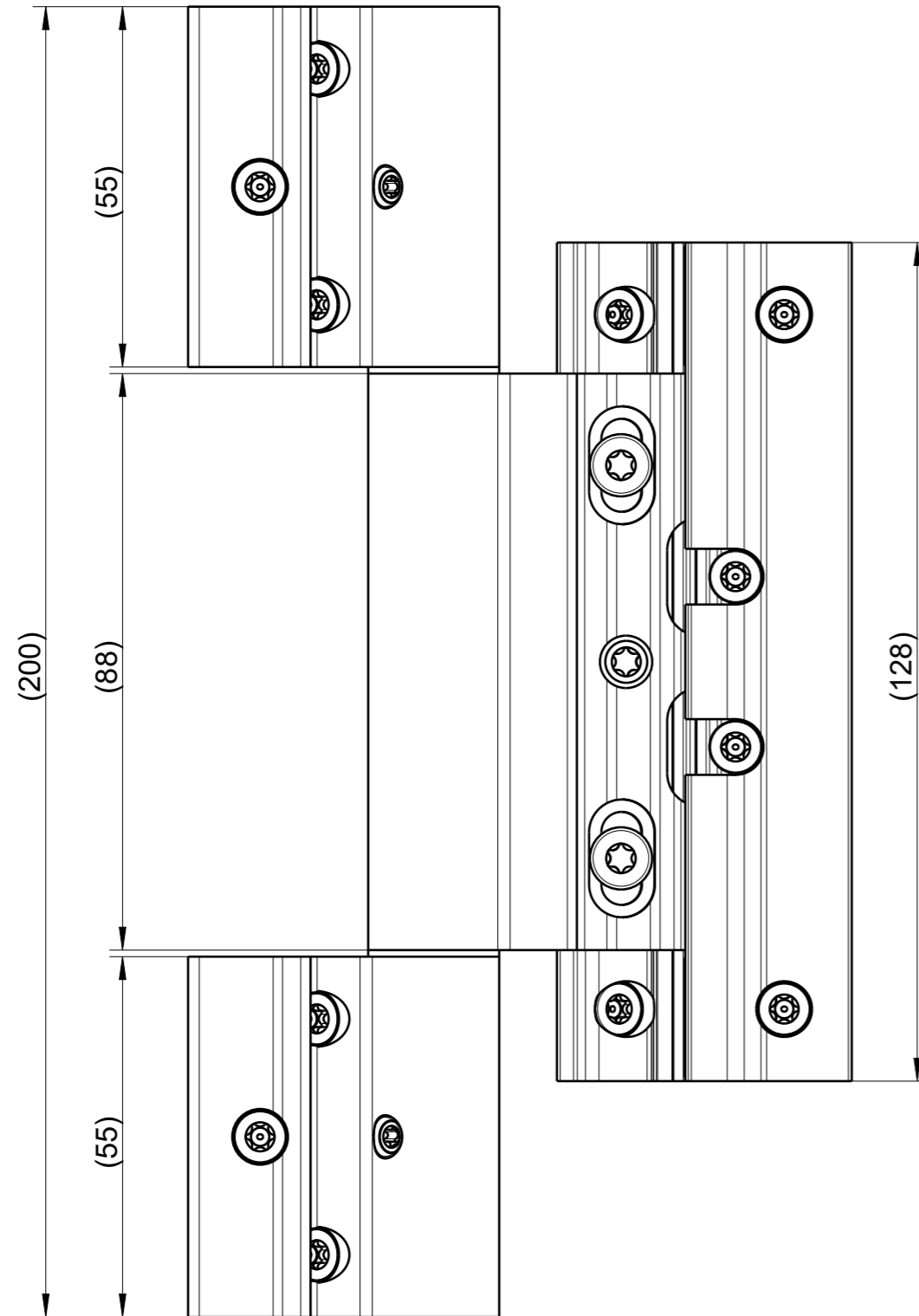

Pos	Menge	Benennung	Sachnummer
1	2	RBT AT 6 / 13,5	R700F0009
2	2	Lagerbuchse FBT exzentrisch schwarz	R600K0001
3	1	FBT Einheit komplett Rollenband AT	90220B0097
4	1	Lagerbolzen	R600E0007
5	2	Gewindestift M6x5-TX15 A4 oder A2	R400E0010
6	12	Bef.-Schraube RB-AT 4,8x16	R700E0000

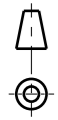
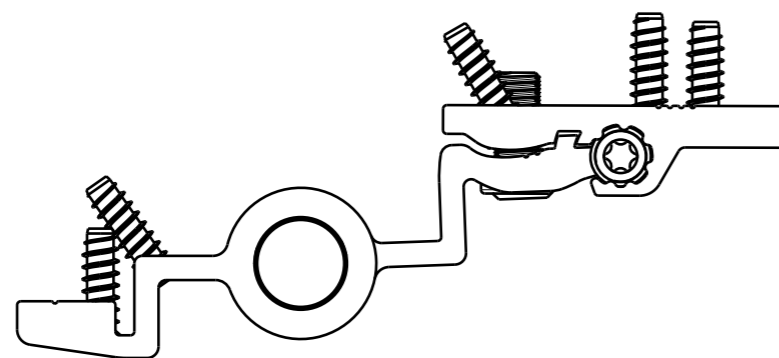
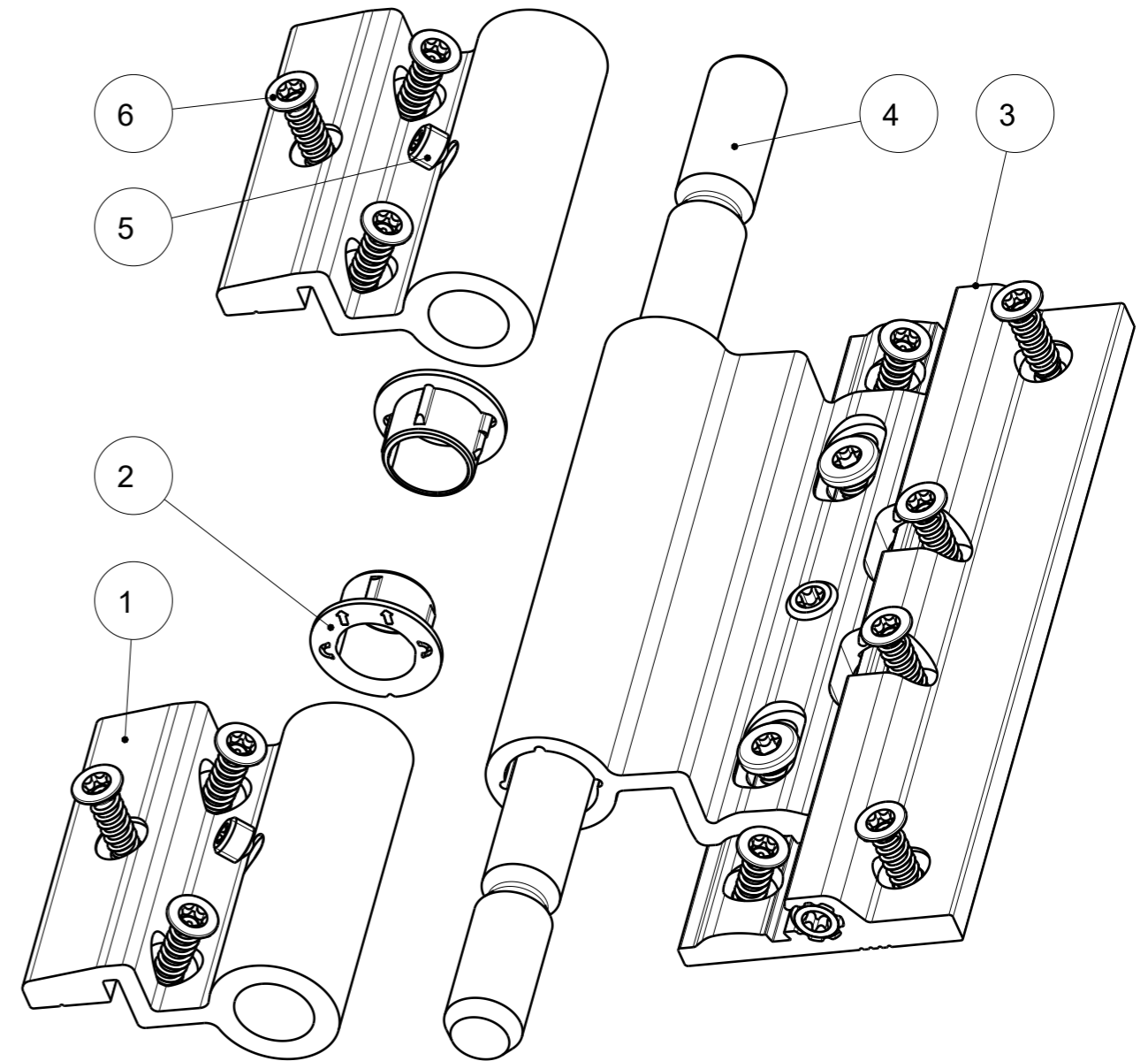

ASSEM

Für diese technischen Unterlagen behalten wir uns alle Rechte nach DIN ISO 16016 vor				Maßstab: 1:1	
				Maße ohne Toleranzangabe nur zur Information	
				Benennung: ROLLERBAND AT	
				Vidnal V72	
				Zeichnungsnummer: 90220_0077	
				Blatt 2	
				Blatt 3	
In.	Änderung	Datum	Name	Urspr.:	Ers.f. Modell-Nr. 90220_0077

Dr. Hahn
TÜRBÄNDER. MADE IN GERMANY.

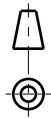
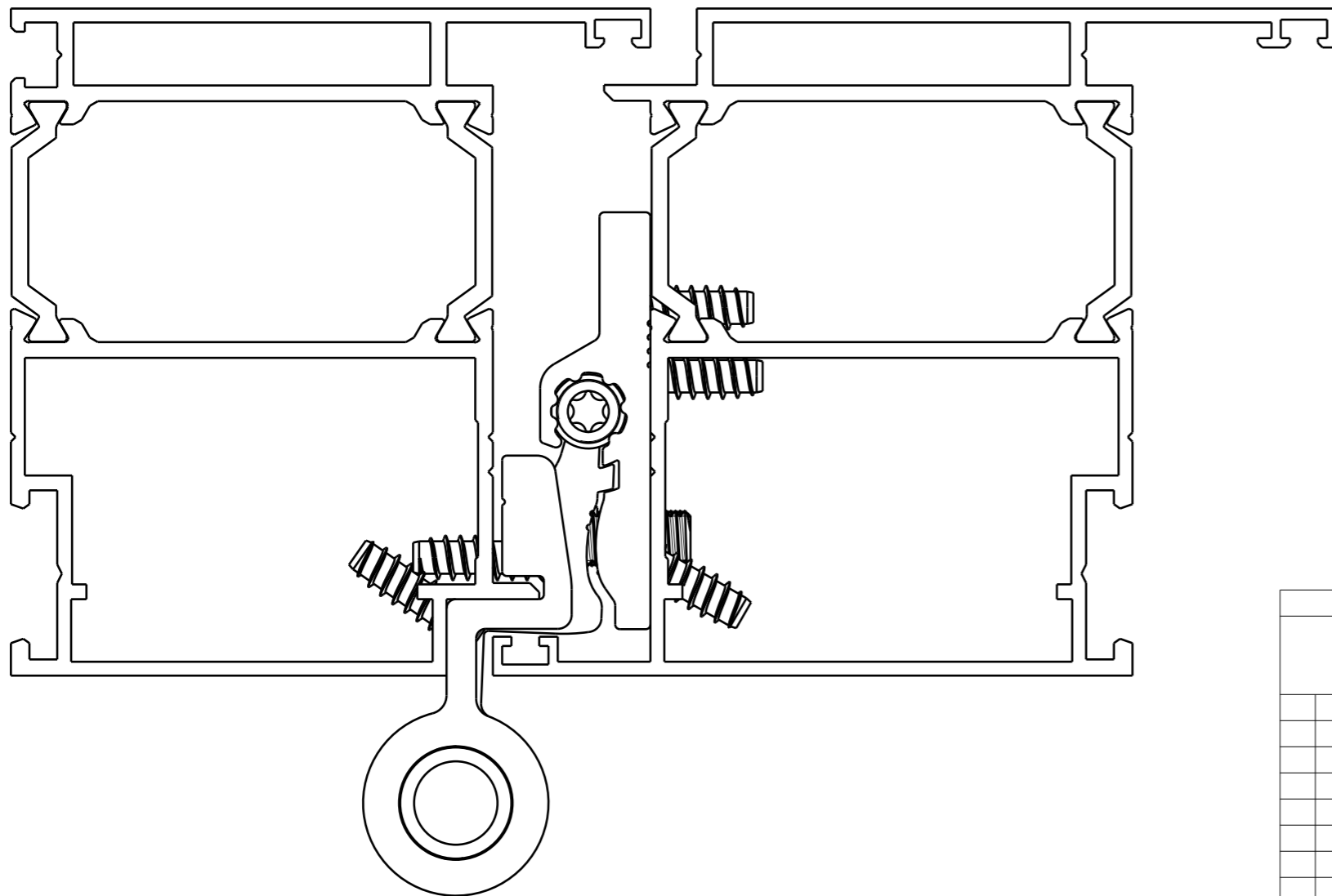
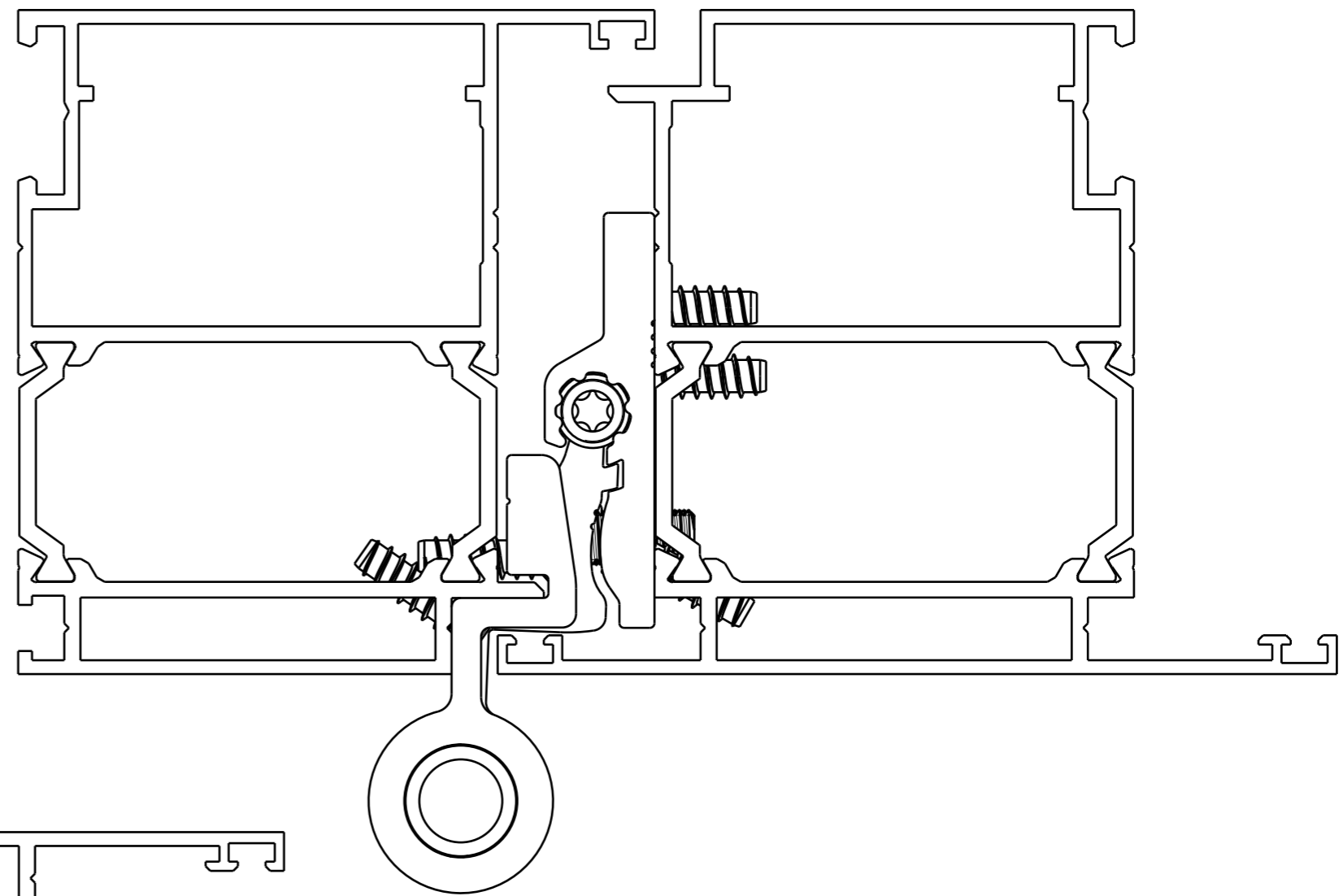

ASSEM

Für diese technischen Unterlagen behalten wir uns alle Rechte nach DIN ISO 16016 vor				Datum		Name		Maßstab: 1,5:1	
				Bear.		Gepr.		DIS:	
				14.07.2020		KUDLA		Benennung: NICHT Freigegeben!	
								Rollenband AT	
								Vidnal V72	
								Zeichnungsnummer:	
								Blatt	
								3	
								3	
								Ers.f.	
								Modell-Nr. 90220_0077	
In.		Änderung		Datum		Name		Urspr.:	



Dr. Hahn[®]
TÜRBÄNDER. MADE IN GERMANY.